

# TFX-2

## INCANDESCENT WET LOCATION POLYCARBONATE EMERGENCY UNIT



### STANDARD

### OPTIONAL



### ILLUMINATION

- Adjustable, glare-free PAR-Type lamp heads with 7.2 watts incandescent wedge base lamps.
- Sealed and gasketed weather proof lamp heads with high performance chrome-plated metalized reflector and tempered glass lenses.

### ELECTRICAL

- Dual 120/277 voltage.
- Charge rate/power "ON" LED indicator light and push-to-test switch for mandated code compliance testing.
- LVD (low voltage disconnect) prevents battery from deep discharge.
- 6V maintenance-free, rechargeable sealed lead acid battery.
- Internal solid-state transfer switch automatically connects the internal battery to lamp heads for minimum 90-minute emergency illumination.
- Fully automatic solid-state, two rate charger initiates battery charging to recharge a discharged battery in 24 hours.

### MOUNTING

- External mounting brackets for simplified surface mounting provide.

### HOUSING

- Corrosion-resistant 5VA flame retardant, UV-stabilized polycarbonate in gray finish.
- Sealed and gasketed housing with hinged cover.
- Sealed test switch.
- Integral breather vent.

### OPTIONS

- HTR: Optional internal heater for cold temperature (-9°C – 40°C) applications.
- USA: Substantial transformation assembly in the U.S. complies with "Assembled in the USA" under the Buy American Act.
- RC: Remote capacity of up to 14.4 watts.

### WARRANTY / LISTING

- Five year warranty on all electronics and housing. Batteries are prorated warranted for two years.
- Meets UL924, NFPA 101 Life Safety Code, NEC, OSHA, Local and State Codes.
- UL Listed for wet locations (5°C – 40°C).

### DIMENSIONS

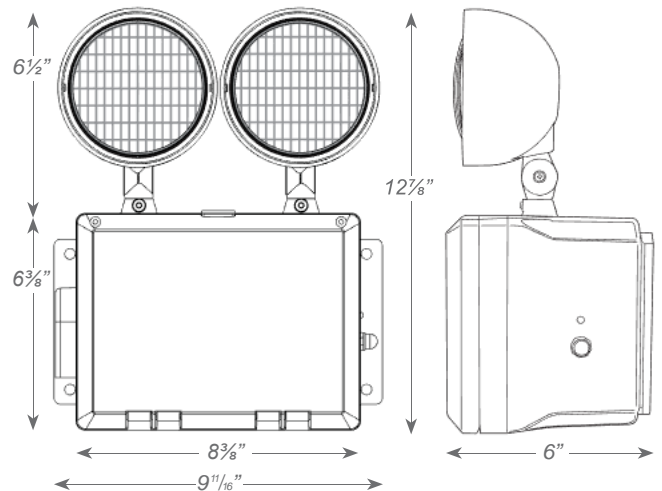

### ORDERING INFORMATION

Sample Part Number: TFX-2

Special voltage options available.

MODEL	OPTIONS
TFX-2	HTR Internal Heater
	USA Assembled In USA
	RC Remote Capacity