

FL-LED-R2B-140PS-8CSB-ST

HIGH-POWER LED FLOODLIGHT



140W High-Power LED Rectangular Floodlight; 120–277V Input

PRODUCT FEATURES

- Selectable wattage technology (140/100W)
- Selectable CCT technology (3000/4000/5000K)
- High power floodlight with innovative design based on established floodlight principles
- Die cast aluminum housing, with optional glare shield accessory (sold separately)
- Heavy duty, interchangeable slipfitter and trunnion mount options included
- Suitable for ground, pole, or building mount applications
- 3-pin twist lock photocell and shorting cap included with NEMA/ANSI C136.10 3-pin twist lock receptacle
- Precision-crafted optics lens with NEMA 7H x 6V, 6H x 6V, and 5H x 5V options available. See below chart for details
- Keystone 0-10V dimming driver with 12V AUX power tap and 6kV surge protection
- Ambient operating temperature: -40°C/-40°F - 50°C/122°F
- UL Certified, IP65 rated
- Power factor: > 0.95
- THD: < 20%
- LED chip lifetime: L70 > 100,000 hrs @ 25°C/77°F ambient fixture temperature
- Meets FCC Part 15, Part B, Class A standards for conducted and radiated emissions



10 YEAR
LIMITED WARRANTY

ELECTRICAL SPECIFICATIONS

Catalog Number	Wattage	CCT	Lumens	Efficacy	Input Voltage	CRI	Dimming	Mounting	Optics Type	Photocell	Rated Life	Legacy Equivalent
FL-LED-R2B-140PS-8CSB-ST	140W	3000K	17,500	125 lm/W	120–277V	>80	0–10V	Universal: 2 3/8" Slip Fitter or Trunnion	7H x 6V	Included	50,000 hours	400W MH
		4000K	20,300	145 lm/W								
FL-LED-R2C-140PS-8CSB-ST	100W	5000K	18,900	135 lm/W								
		3000K	13,500	135 lm/W								
		4000K	15,500	155 lm/W								
FL-LED-R2D-140PS-8CSB-ST		5000K	14,500	145 lm/W								

Note: fixtures with 6H x 6V or 5H x 5V optics are assembled to order. Lead times may apply.

FL-LED-R2B-140PS-8CSB-ST

HIGH-POWER LED FLOODLIGHT

DIMENSIONS

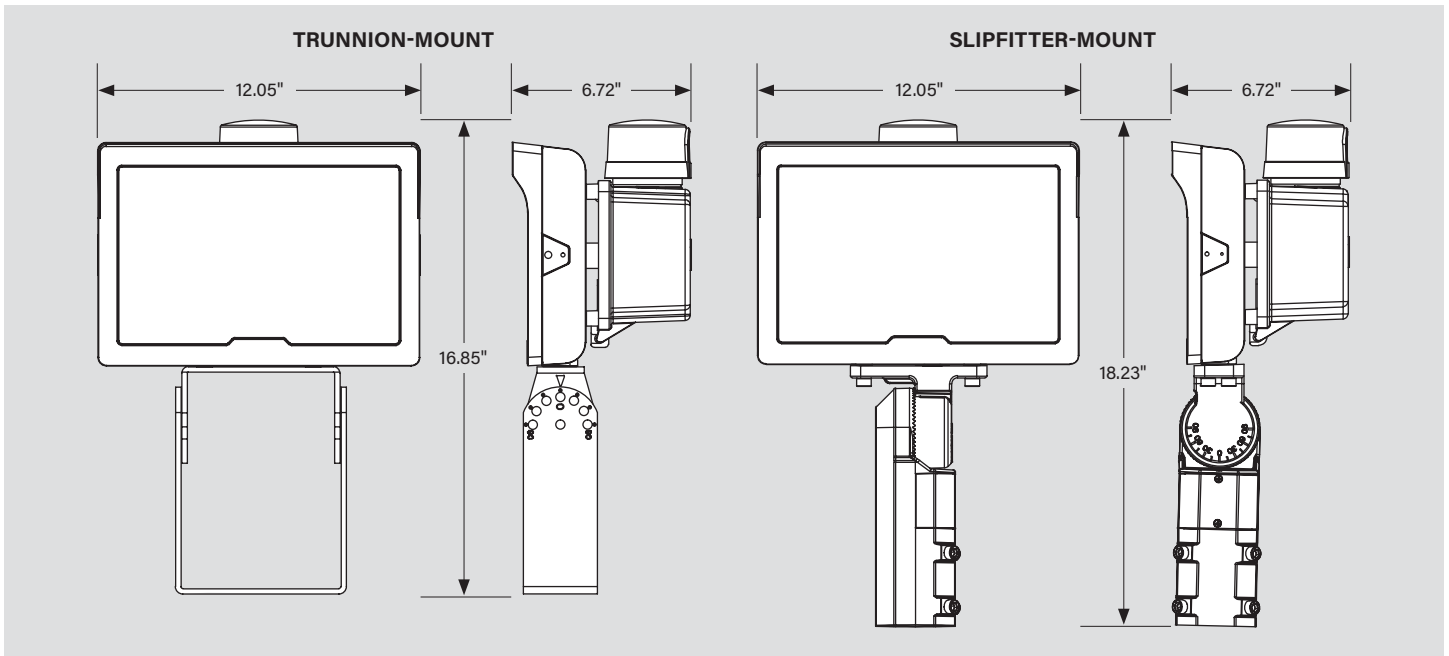

SELECTABLE WATTAGE AND SELECTABLE CCT ADJUSTMENT INSTRUCTIONS

This fixture is equipped with field-adjustable selectable wattage and selectable CCT technology.

1. Ensure power is off to the fixture.
2. Unscrew the gasketed caps from the back of the fixture as shown in the images below.
3. Adjust dip switches to desired settings.
4. Screw on gasketed caps.
5. Restore power to fixture.

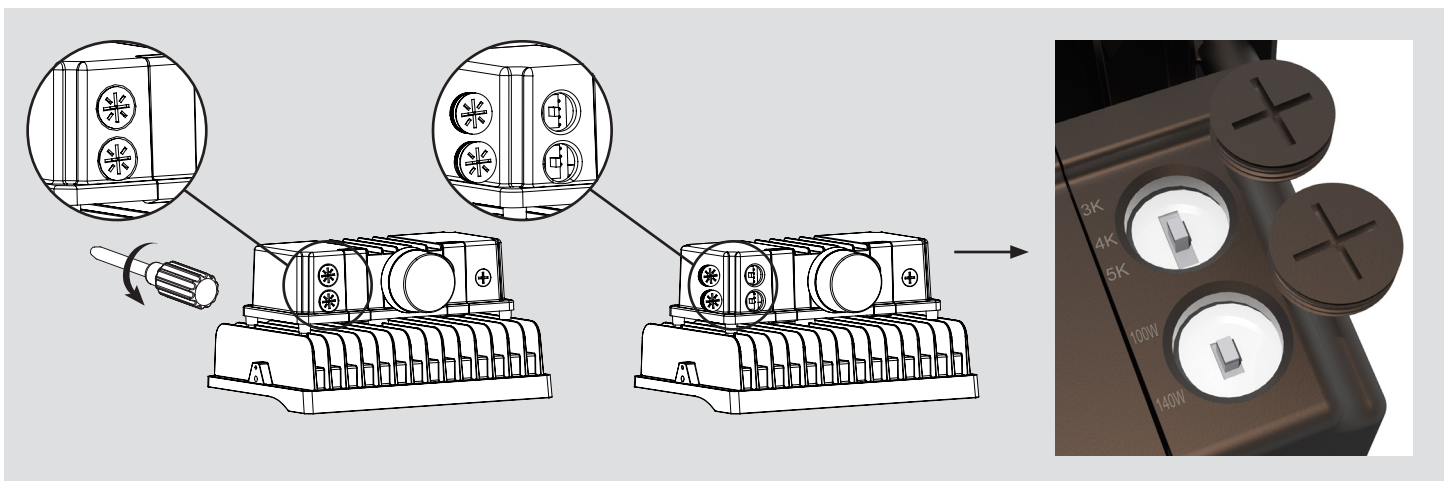

FL-LED-R2B-140PS-8CSB-ST

HIGH-POWER LED FLOODLIGHT

PHOTOCELL INSTRUCTIONS

This fixture comes with a 3-pin twist-lock photocell accessory.

This fixture is compatible with NEMA/ANSI C136.10-2010 3-pin twist-lock photocells.

1. Ensure power is off to the fixture.
2. Remove existing twist lock shorting cap from receptacle.
3. Push the photocell onto the receptacle and twist clockwise to lock into place.
4. For optimal performance, install the photocell with sensor director facing north as indicated on the top of the accessory. Adjust if necessary, while ensuring proper water-tight install.
5. Restore power to fixture when ready.

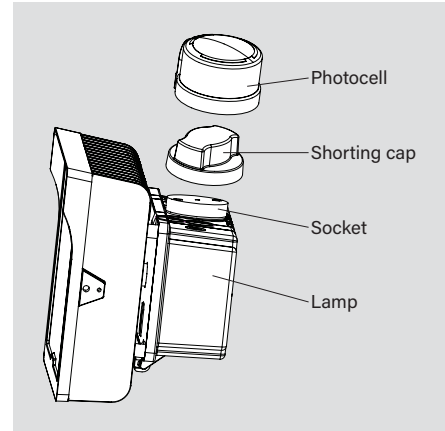

WIRING DIAGRAMS

GENERAL WIRING DIAGRAM

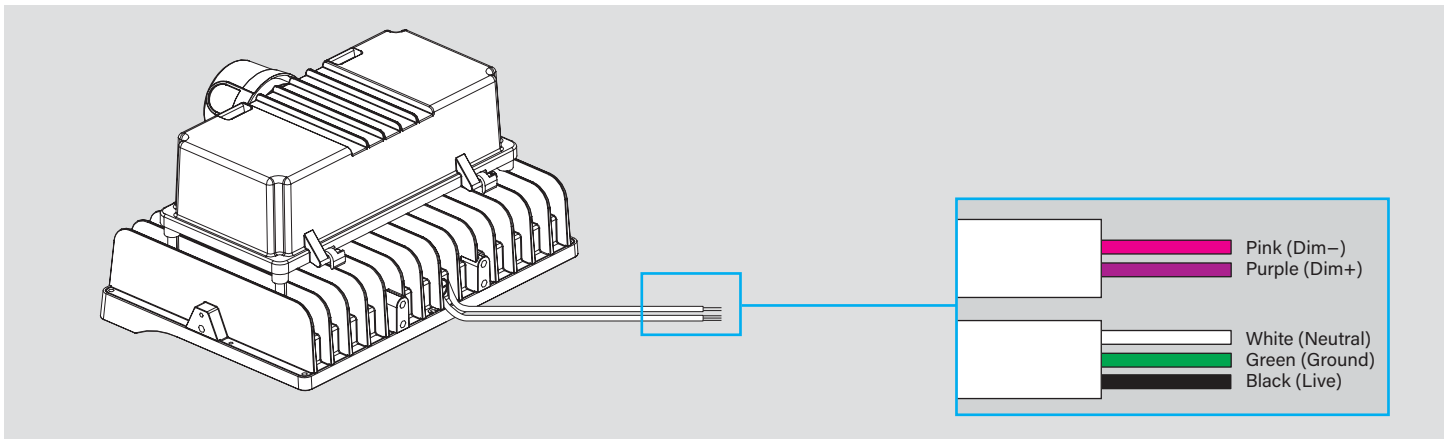
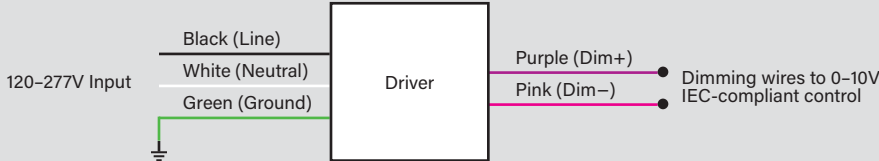





EPA SPECIFICATIONS

Small-Size Fixture Housing

- Conditions: Horizontal winds only for calculations. Worst case total projected area used for calculations.
- All drag coefficients are set as worst case 1.2.
- For details on exact EPA calculations and assumptions, please contact productsupport@keystonetech.com

EPA Calcs (1.2*ft^2 | View)

Mounting Application	Fixture Position	Housing Size	Single Fixture	2 Fixtures at 90°	2 Fixtures at 180°
					
Slip Fitter Mount 	45°	S (140W)	1.089 sq. ft.	1.778 sq. ft.	1.377 sq. ft.

FL-LED-R2B-140PS-8CSB-ST

HIGH-POWER LED FLOODLIGHT

LIGHT DISTRIBUTION PATTERN

BUILDING-MOUNT VIEW FROM ABOVE

Floodlight mounted at 30' above ground; beam angled 30° below horizontal

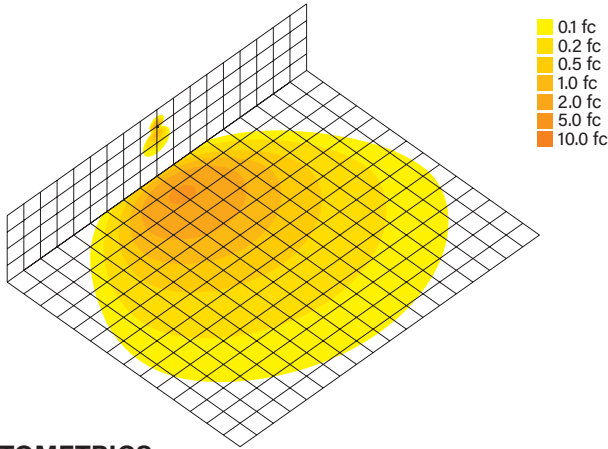

GROUND-MOUNT VIEW FROM ABOVE

Floodlight mounted at 6" above ground; beam angled 10° above horizontal; shining toward building wall from 35' away

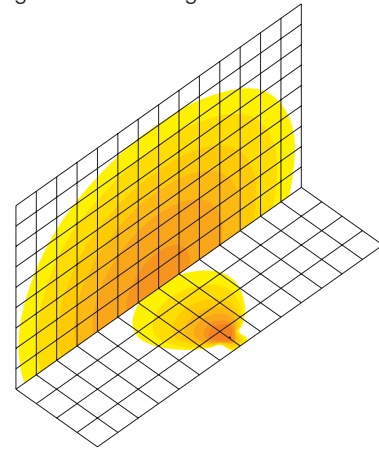

PHOTOMETRICS

Luminous Intensity Distribution Curve

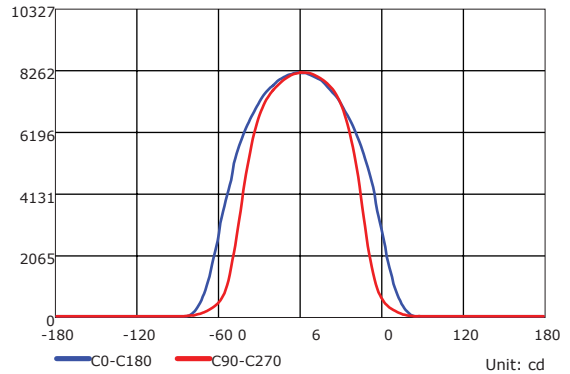
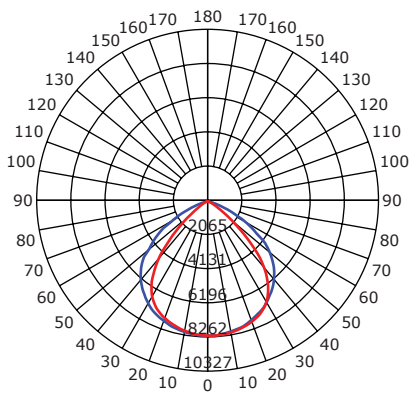

Illuminance at a Distance

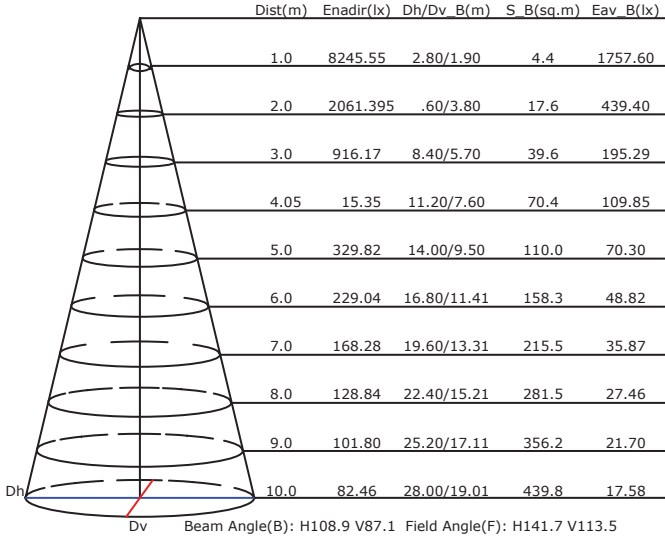

Isocandela (Rectangle)

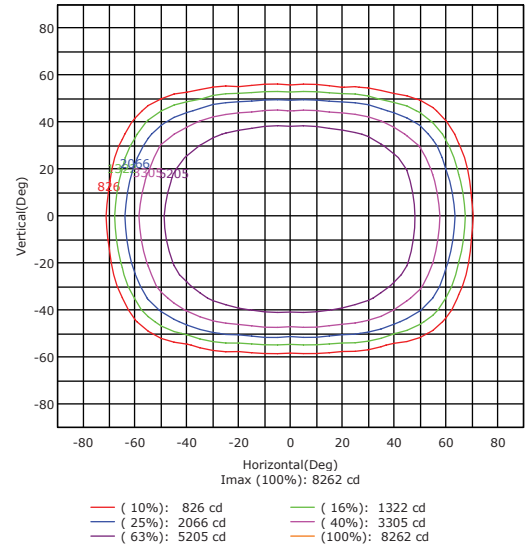

HIGH-POWER LED FLOODLIGHT ORDERING INFORMATION

Catalog Number	Pack Qty.	UPC
FL-LED-R2B-140PS-8CSB-ST	1	843654148700
FL-LED-R2C-140PS-8CSB-ST	1	843654148724
FL-LED-R2D-140PS-8CSB-ST	1	843654148731